

GQA90SC 90cm Slim Line Canopy

Functions and features

- 1200 cubic metres per hour extraction
- Ceiling cavity motor for silent operation
- Low consumption LED lights x 6 **NEW**
- Outlet diameter 150 mm
- 3 Speed fan
- 3 dishwasher safe stainless steel filters
- 2 year warranty - 7 Year motor warranty
- Ready to go. Easy to install.

www.glemgas.com.au

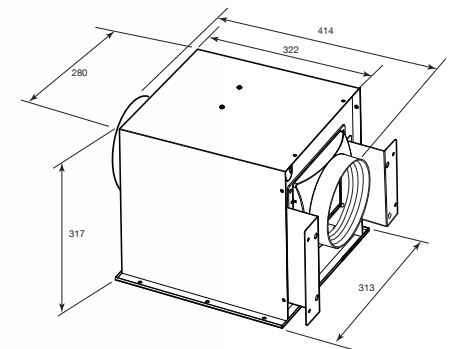
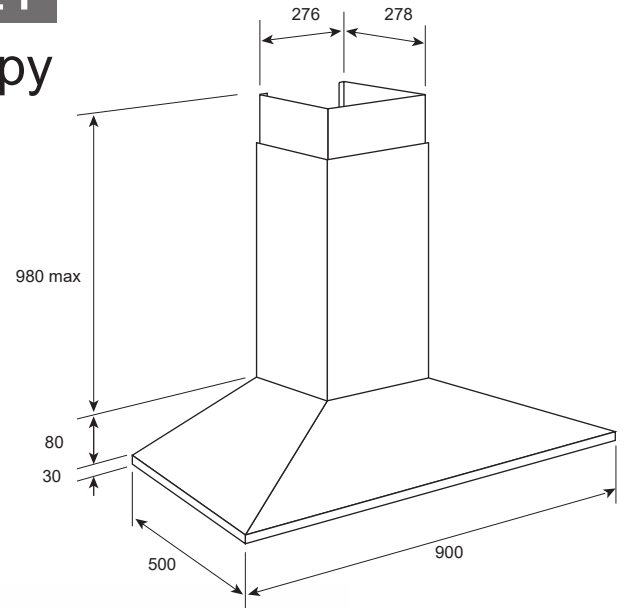

Remote fan motor goes into ceiling space



Filter hinge safety system



Mesh filter option included



Full installation kit included except external vent
2 Lengths of ducting 1.5 m + 2.5 m lengths
Total Cable length motor unit to rangehood = 3.8 m

Packaging details - single carton

Weight KG	Length M	Width M	Height M
26.8	0.975	0.495	0.58

Please note:
Every effort has been made to ensure this information is correct. However, due to constant product improvement we reserve the right to make changes to products without prior notice.